

CH-1. X3300W units



X3300CC : Command center control system.
 A. Available in Black and Tan color.
 B. Uses 2 x AA batteries.



X3300MF : Muzzle Flamer /Tracer Unit.
 A. Available in Black Color
 B. Uses 4 x AAA, Alkaline or Eneloop batteries



X3300SCU (optional): Shot Control Unit (SCU)
 Controls burst mode through the by command center. Module.

**** The X3300CC and X3300MF has paired in factory. That can't mix CC and MF with else.**

CH-2. Installation

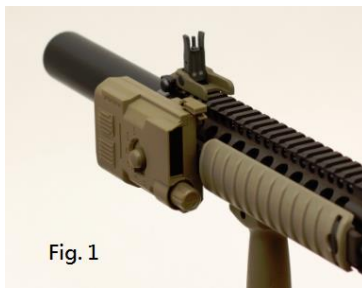

Fig. 1

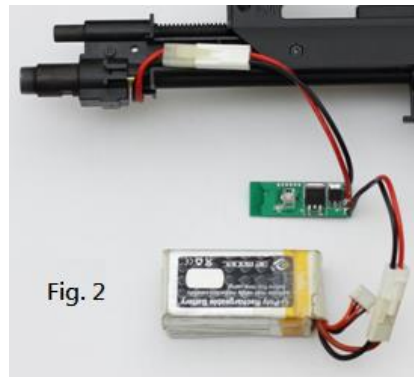

Fig. 2

● X3300W install :

1. Install X3300MF on the reverse 14mm thread of AEG barrel (Fig. 1)
2. Install X3300CC on your AEG's tactical rail (Fig. 1)
3. Connect the X3300SCU to the AEG's Battery (Fig. 2) - (optional).
4. Turn on the X3300MF and X3300CC power
5. Configure the X3300CC settings
6. X3300CC and X3300SCU need to be linked together after binding/pairing
7. X3300SCU controls burst mode with low-voltage protection (optional)

● X3300CC and X3300SCU binding /pairing:

1. Set the X3300CC "Mode Selector" to "ST", rotate the "Data Wheel" to ScU then push the "Data Wheel", select to "MEM" and push the "Data Wheel"
 2. In "MEM", select Memory 1 ~ 8
 Ex: Select "1" then "Data Wheel"
 3. Rotate "Data Wheel" to select, "bind" will display "[1]", in the "[]" flashing
 4. Push X3300SCU switch on the PCB
 5. X3300CC displays a "[1]" that will flash repeatedly, indicating settings are complete
 6. The X3300CC has 8 memory channels for binding/pairing
- ※ Reference "X3300W ScU shot control unit in Ch5

CH-3. X3300W Kits operation

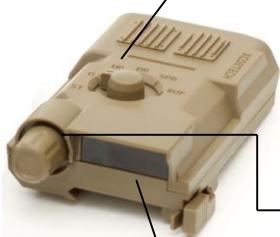

X3300CC operation:

- Mode Selector:
 1. ROF (roF) : Displays rate of fire (Rounds per-minute)
 2. SPD (SPd) : Displays BB Velocity
 3. DN (dn) : Display count down
 4. UP (UP) : Display count up
 5. 0 (oFF) : Power off
 6. ST (SEt) : Set Command center
- Data Wheel (pushable): Rotate the "Data Wheel" to set the Data
 1. In ROF/SPD/DN/UP mode :
 - A. Rotate "Data Wheel" : To adjust screen brightness
 - B. Push and hold 2sec : To reset UP and preset DN count.
 - C. Quickly push "Data Wheel" 3 times :
 To select Burst/Auto firing mode (Display shows brSt / AUto)
 2. In ST mode :
 - A. Rotate "Data Wheel" : Select parameter or set it.
 - B. Push "Data Wheel" : To confirm the parameter.
- Display 4 Digits-Display



X3300MF operation

- Power : ON/OFF
 - Power indicator : Green light is running, Red light indicates low battery
- Unit will Auto power off if not used for 10 mins
- Inner barrel length to insert Max 40mm

X3300SCU operation

- Binding/pairing SW



CH-4. X3300CC Setup operation

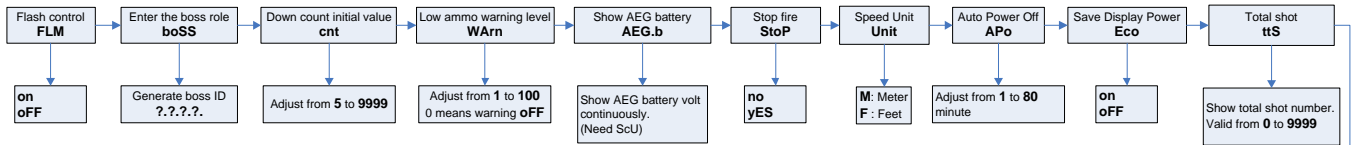

Mode Selector select to ST (Setup Mode)

That can be setup below function (reference above flowchart for setup)

- **FLM** (flash control) : on/off, Setup Tracer BB on/off
- **boSS** : Team Battle Mode to limit team for BB counts
Link: <http://youtu.be/leCexUHqETO>
- **cnt** (count): 5-9999, Preset initial count down value
- **WArn** (warn): 1-100 & oFF, low ammo warning
(When low ammo warning, display will flash in count down mode)
- **AEG.b** (AEG battery): Display AEG's battery voltage
(need to link with X3300SCU)
- **Unit**: M/F, Set unit for speed (meter/sec , feet/sec)
- **APo** (auto power off): 1-80 mins, Set auto power off
- **Eco** (save display power): on/off, auto adjust the screen brightness to maximize battery life
- **ttS** (total shot count): 0-65000, Display total count, push and hold the "Data Wheel" 3 sec to reset count.
- **ScU** (Shot Control Unit): Set burst round shot
(see Ch5)
- **rSt** (reset): Reset to factory setting

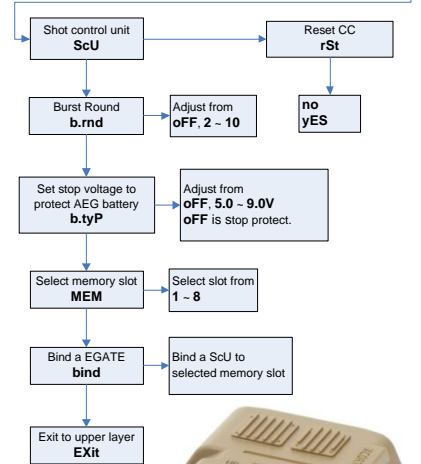

CH-5. * X3300W ScU (shot control unit) setup

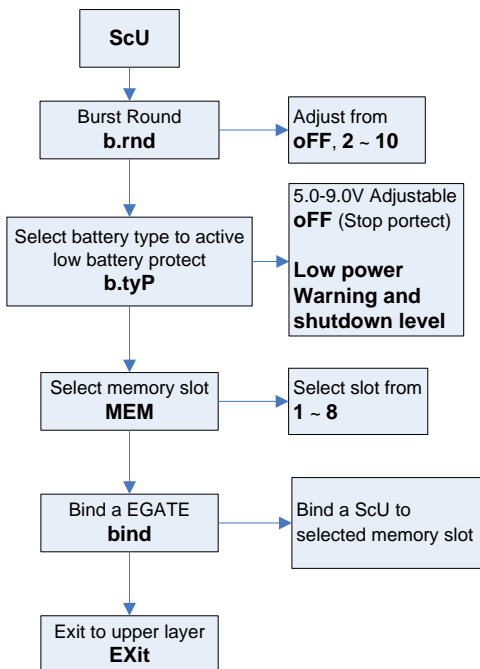

※Need to connect X3300SCU (optional)

- **b.rnd** : oFF & 2-10 : Burst fire setting 2-10.
- **b.tyP** : 5.0-9.0 Voltage & oFF : Set low power level. The AEG will vibrate and shutdown when lower battery level is detected. Select oFF to disable this function.
- **MEM** : 1-8 : Set burst control channel, each channel includes the following factors:
cnt value
Warn value
b.rnd number
b.tyP select
bind information
- **bind** : Binding/paring with X3300SCU
- **Exit** : Exit

SCU setting Video: <http://youtu.be/BJZ32J4UbQA>
The Xcortech product information : <http://goo.gl/W11L0K>

Binding X3300W and X3300SCU

